

# 고정판

STOPPER PLATES

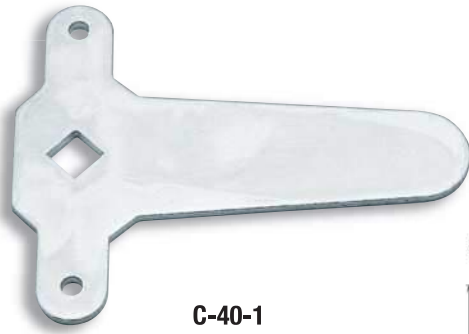

## C-40-1(ss)·SC-40-1(sus)



C-40-1

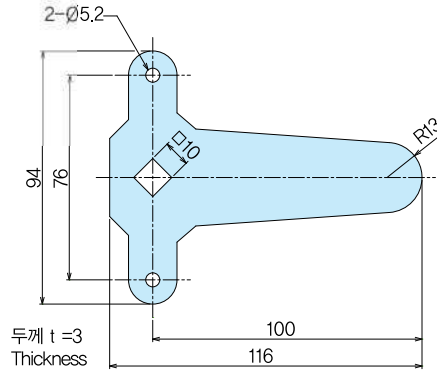

재 질 ●C-40-1/철 (SPHC) 3t  
●SC-40-1/스테인레스 (SUS304) 3t  
표 면 처 리 ●C-40-1/백색아연도금  
Material ●C-40-1/Hot rolled steel plate (SPHC)3t  
●SC-40-1/Stainless steel plate (SUS304) 3t  
Fin ish ●C-40-1/Plating

품번 Product No.	중량(g) Weight	입수 Lot
C-40-1	105	50
SC-40-1	102	50

## C-40-2(ss)·SC-40-2(sus)

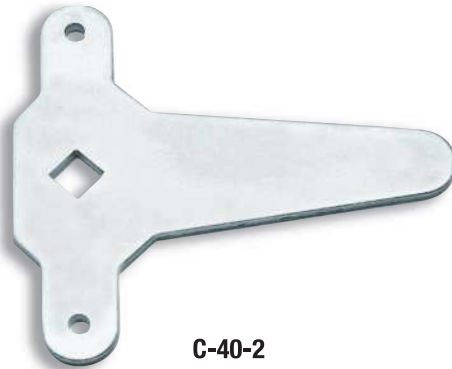

C-40-2

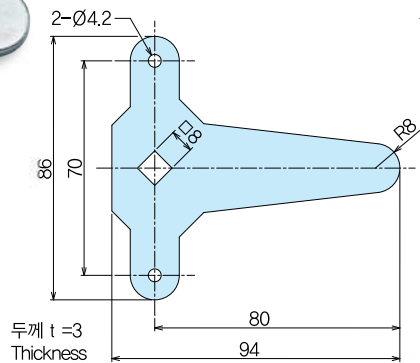

재 질 ●C-40-2/철 (SPCC) 3t  
●SC-40-2/스테인레스 (SUS304) 3t  
표 면 처 리 ●C-40-2/백색아연도금  
Material ●C-40-2/Cold rolled steel plate (SPCC) 3t  
●SC-40-2/Stainless steel plate (SUS304) 3t  
Fin ish ●C-40-2/Plating

품번 Product No.	중량(g) Weight	입수 Lot
C-40-2	76	50
SC-40-2	72	50

## C-41(ss)·SC-41(sus)



SC-40-1

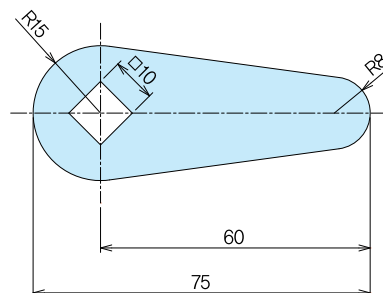

재 질 ●C-41/철 (SPCC) 2.3t  
●SC-41/스테인레스 (SUS304) 2t  
표 면 처 리 ●C-41/백색아연도금  
Material ●C-41/Cold rolled steel plate (SPCC)2.3t  
●SC-41/Stainless steel plate (SUS304) 2t  
Fin ish ●C-41/Plating

품번 Product No.		□K	중량(g) Weight		입수 Lot	
SS	SUS		SS	SUS	SS	SUS
C-41-1	SC-41-1	10	27.3	23.3	100	50
C-42-2	SC-42-2	8	26.9	24.2	100	100