

고정판

STOPPER PLATES



C-1(SS)·SC-1(SUS)



C-1-1

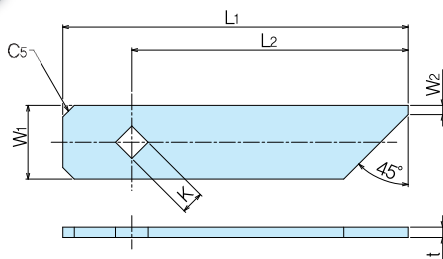

재 질 ●C-1/철(SPHC)
●SC-1/스테인레스(SUS304)
표 면 처 리 ●C-1/백색아연도금
Material ●C-1/Hot rolled steel plate (SPHC)
●SC-1/Stainless steel(SUS304)
F i n i s h ●C-1/Plating

품번 Product No.		L1	L2	W1	W2	□K	t		중량(g) Weight		입수 Lot
SS	SUS						SS	SUS	SS	SUS	
C-1-1	SC-1-1	150	120	32	4	10	4.5	4	143.8	129.2	50
C-1-2	SC-1-2	140	115	32	4	8	4.5	4	134.1	120.7	50
C-1-3	SC-1-3	97	78	26	3	8	3.2	3	52.8	49.3	50

C-2(SS)·SC-2(SUS)



C-2-2

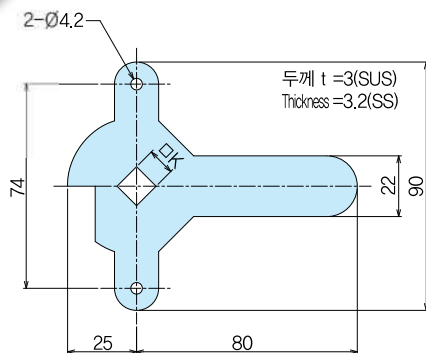

재 질 ●C-2/철(SPHC) 3.2t
●SC-2/스테인레스(SUS304) 3t
표 면 처 리 ●C-2/백색아연도금
Material ●C-2/Hot rolled steel plate (SPHC) 3.2t
●SC-2/Stainless steel (SUS304) 3t
F i n i s h ●C-2/Plating

품번 Product No.		□K	중량(g) Weight		입수 Lot
SS	SUS		SS	SUS	
C-2-2	SC-2-2	10	81.5	76.3	50
C-2-3	SC-2-3	8	83.1	77.9	50

C-2(小)(SS)



C-2-2(小)

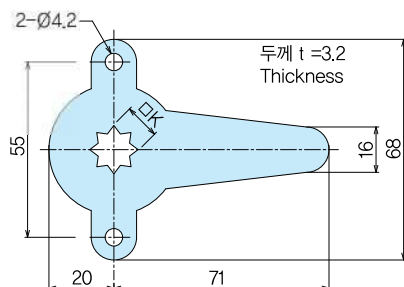

재 질 ●C-2(小)/철(SPHC)3.2t
표 면 처 리 ●백색아연도금
Material ●C-2(小)/Hot rolled steel plate (SPHC) 3.2t
F i n i s h ●Plating

품번 Product No.	L (mm)	중량(g) Weight	입수 Lot
C-2-2(小)	10	62.9	50
C-2-3(小)	8	63.8	50