

매미형 스프링 열쇠캐치

CATCH CLIPS

DP-801(ss)·SDP-801~802(sus)



DP-801

SDP-801~802

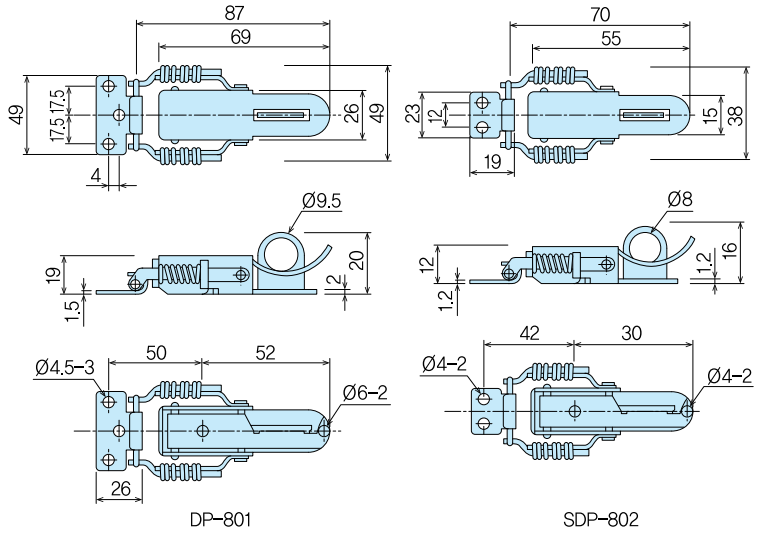

- 재 질 ●DP-801/철(SS)
 ●SDP-801~802/스테인레스(SUS)
 표 면 처 리 ●DP-801/황색아연도금
 ●SDP-801~802/헤어라인 연마

- Material ●DP-801/Rolled steel(SS)
 ●SDP-801~802/Stainless steel(SUS)
 F i n i s h ●DP-801/Zinc chromate plating
 ●SDP-801~802/Hairline

매미형 스프링 캐치

CATCH CLIPS

DP-803~804(ss)·SDP-803~804(sus)



DP-803

DP-804

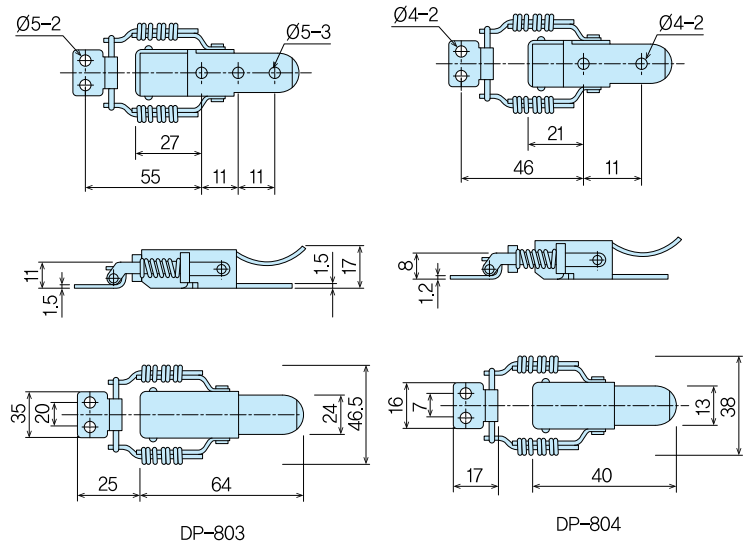

- 재 질 ●DP-803~804/철(SS)
 ●SDP-803~804/스테인레스(SUS)
 표 면 처 리 ●DP-803~804/백색아연도금
 ●SDP-803~804/헤어라인 연마

- Material ●DP-803~804/Rolled steel(SS)
 ●SDP-803~804/Stainless steel(SUS)
 F i n i s h ●DP-803~804/Zinc unichromate plating
 ●SDP-803~804/Hairline