

스테이

STAYS

SC-160-1(sus)

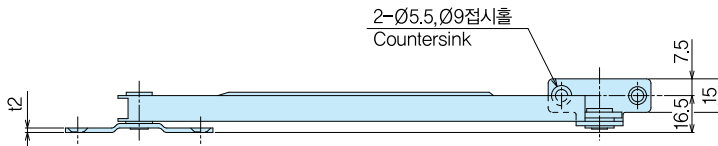
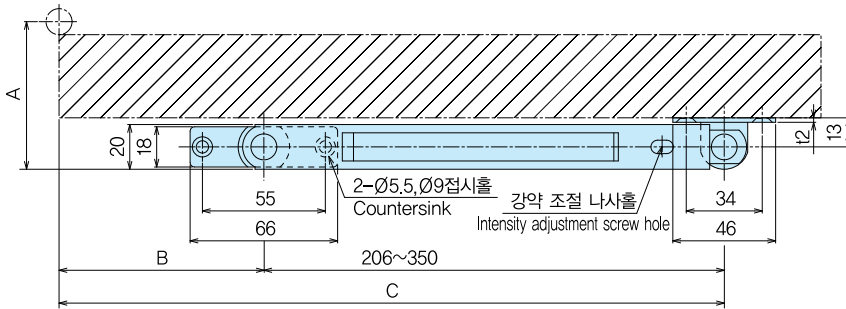

●90도 개방형의 경우
Case of 90° opening

A	25	30	35
B	100	95	90
C	306	301	296

- 특징**
Feature
- 회전공간이 없는 경우에 적합합니다.
 - 문의 중량등에 의한 개폐시의 강약 조절이 간단합니다.
 - 조정은 최대한으로 문을 연 상태에서 해 주십시오.
 - 위로 여는 방식, 아래로 여는 방식, 옆으로 여는 방식등 어떤 곳이라도 사용 가능합니다.
- Suitable for no turning space.
●It can be stopped at your required position when you open the door.
●Strength by weight of the door can be adjusted easily when opening or closing.
●(Please adjust in a state of maximum opening)
●Any types (opening type-top/bottom/side) can be used in all of boxes.

- 재질**
Material ●스테인레스(SUS 304)
- 표면처리**
Finish ●헤어라인
- 용도**
Specific Use ●열람실, 회전실, 밀어 내는 식의 공간, 천장용, 주방기구, 점검구 등설치차수표

- Material** ●Stainless steel (SUS 304)
- Finish** ●Hairline
- Specific Use** ●Vacancy rooms, turning rooms, stays for skylight, kitchen equipments, inspection entrances, etc.
- Remarks** ●Lightweight aluminum doors, wood doors

품번 Product No.	중량(g) Weight	입수 Lot
SC-160-1	185	

C-200-S20(ss)



본 제품은 좌우 있음. (Left or right type are available.)
사진은 왼쪽 취부(L)를 가리킴. (Picture shows the left type.)

- 특징**
Feature ●좌측용과 우측용이 있습니다.
- The left type or right type.
- 재질**
Material ●C-200-S20/철(SPCC)
- 크롬도금
- C-200-S20/Cold rolled steel plate(SPCC)
- Chrome plating

품번 Product No.	중량(g) Weight	입수 Lot
C-200-S20	122	

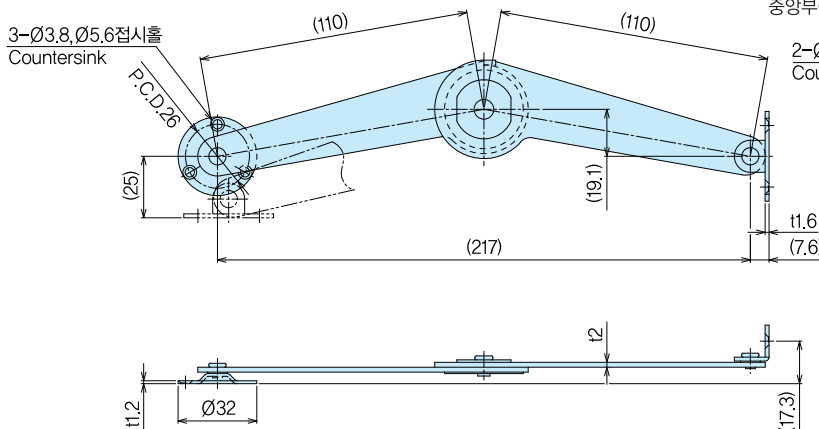

본 그림은 왼쪽 취부(L)를 가리킴. Drawing shows the left type.
중앙부에 잠금기구가 달려있습니다. The structure lock is adopted to the center.

